

| SPECIFICATION |                       |          |            |
|---------------|-----------------------|----------|------------|
| MODEL NAME    | NHM-20                | OPTION   | FLANGE     |
| FAN SPEC.     |                       |          |            |
| FAN DIVISION  | TURBO FAN             |          |            |
| AIR VOLUME    | 20 CMM                | STATIC   | 180 mmAq   |
| MOTOR         | 1.5 kw [ 2 HP ]       | POWER    | 220V x 2P  |
| FILTER SPEC.  |                       |          |            |
| 1ST           | AL DEMISTER           | MATERIAL | AL         |
|               | SIZE 610 x 610 x 20t  | AREA     | -          |
| 2TH           | CARBON MAT            | MATERIAL | CARBON MAT |
|               | SIZE 610 x 610 x 20t  | AREA     | -          |
| 3TH           | HEPA FILTER           | MATERIAL | GLASS      |
|               | SIZE 610 x 610 x 150t | AREA     | -          |

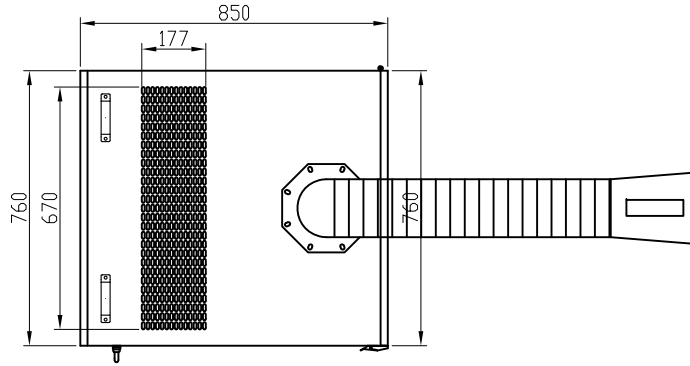

|    |               |   |                         |
|----|---------------|---|-------------------------|
| 1  | HANDEL        | 1 | 25A PIPE                |
| 2  | OUTLET        | 1 | PUNCHING PLATE 8x20     |
| 3  | CABINET       | 1 | 800 x 760 x 760 x 1.6t  |
| 4  | CONTROL PANEL | 1 | ON/OFF SWITCH           |
| 5  | POWER CABLE   | 1 | V.C.T.F CABLE           |
| 6  | TURBO BLOWER  | 1 | 1.5kw x 20CMM x 180mmAq |
| 7  | CASTER        | 4 | ROTATION 3° STOPPER     |
| 8  | ARM 2M        | 1 | Ø150                    |
| 9  | HEPA FILTER   | 1 | 610 x 610 x 150t        |
| 10 | CARBON MAT    | 1 | 610 x 610 x 20t         |
| 11 | DEMISTER      | 1 | A.L. 610 x 610 x 20t    |

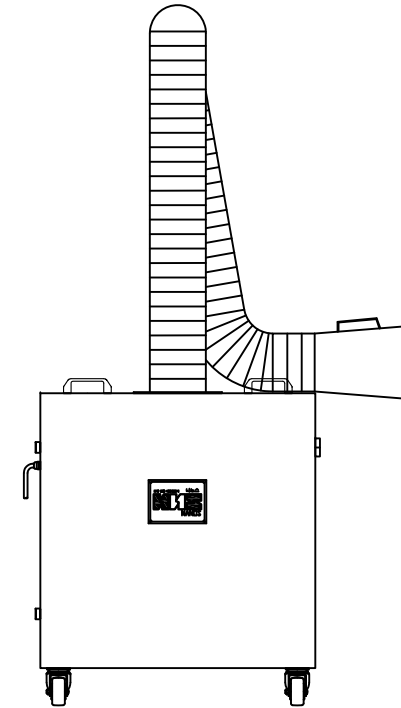
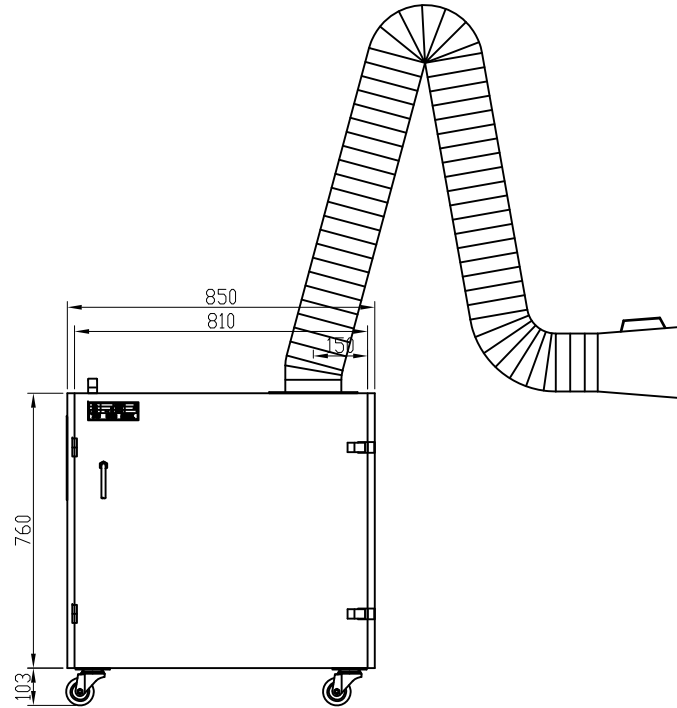
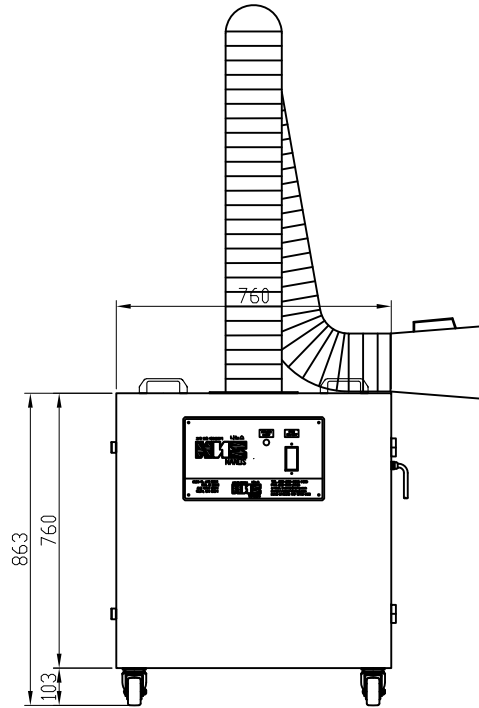

\*\*\* PAINT COLOR \*\*\*  
 BODY : EX8816(S) 5Y 7/1  
 DOOR : EX8816-DIC546 1/2

|                                     |          |          |          |                    |
|-------------------------------------|----------|----------|----------|--------------------|
| <br>고객맞춤 대표 장비기<br>www1-nanos.co.kr | SIZE     | A3       | CUSTOMER | -                  |
|                                     | SCALE    | 1 / 1    | TITLE    | HUM DUST COLLECTER |
|                                     | DRAWN    | APPROVED | NANOS    | DWG. NO.           |
|                                     | B.B.M    | -        |          | NHM-20             |
|                                     | 12.05.18 | -        |          |                    |

| SPECIFICATION |                 |                  |           |            |
|---------------|-----------------|------------------|-----------|------------|
| MODEL NAME    | NHM-30          | OPTION           | FLANGE    |            |
| FAN SPEC.     |                 |                  |           |            |
| FAN DIVISION  | TURBO FAN       |                  |           |            |
| AIR VOLUME    | 40 CMM          | STATIC           | 230 mmAq  |            |
| MOTOR         | 2.2 kw [ 3 HP ] | POWER            | 220V x 2P |            |
| FILTER SPEC.  |                 |                  |           |            |
| 1ST           | AL DEMISTER     |                  | MATERIAL  | AL         |
|               | SIZE            | 610 x 610 x 20t  | AREA      | -          |
| 2TH           | CARBON MAT      |                  | MATERIAL  | CARBON MAT |
|               | SIZE            | 610 x 610 x 20t  | AREA      | -          |
| 3TH           | HEPA FILTER     |                  | MATERIAL  | GLASS      |
|               | SIZE            | 610 x 610 x 292t | AREA      | -          |

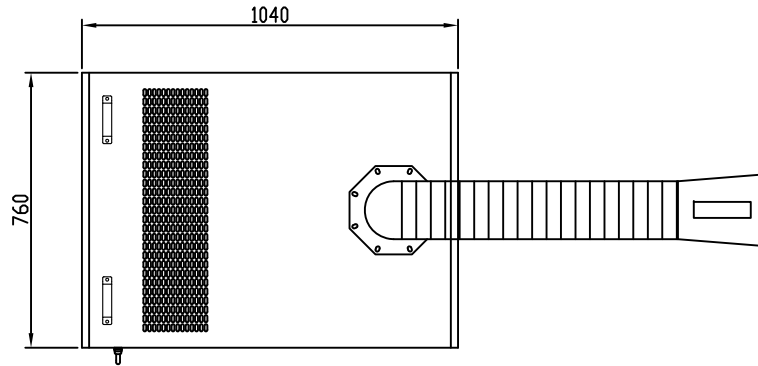

|    |               |   |                         |
|----|---------------|---|-------------------------|
| 1  | HANDEL        | 1 | 25A PIPE                |
| 2  | OUTLET        | 1 | PUNCHING PLATE 8x20     |
| 3  | CABINET       | 1 | 1040 x 760 x 760 x 1.6t |
| 4  | CONTROL PANEL | 1 | ON/OFF SWITCH           |
| 5  | POWER CABLE   | 1 | V.C.T.F CABLE           |
| 6  | TURBO BLOWER  | 1 | 2.2kw x 40CMM x 230mmAq |
| 7  | CASTER        | 4 | ROTATION 3° STOPPER     |
| 8  | ARM 2M        | 1 | ø150                    |
| 9  | HEPA FILTER   | 1 | 610 x 610 x 292t        |
| 10 | CARBON MAT    | 1 | 610 x 610 x 20t         |
| 11 | DEMISTER      | 1 | A.L. 610 x 610 x 20t    |

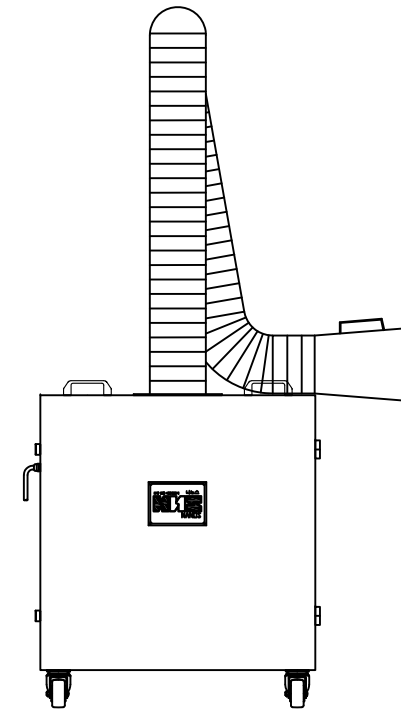
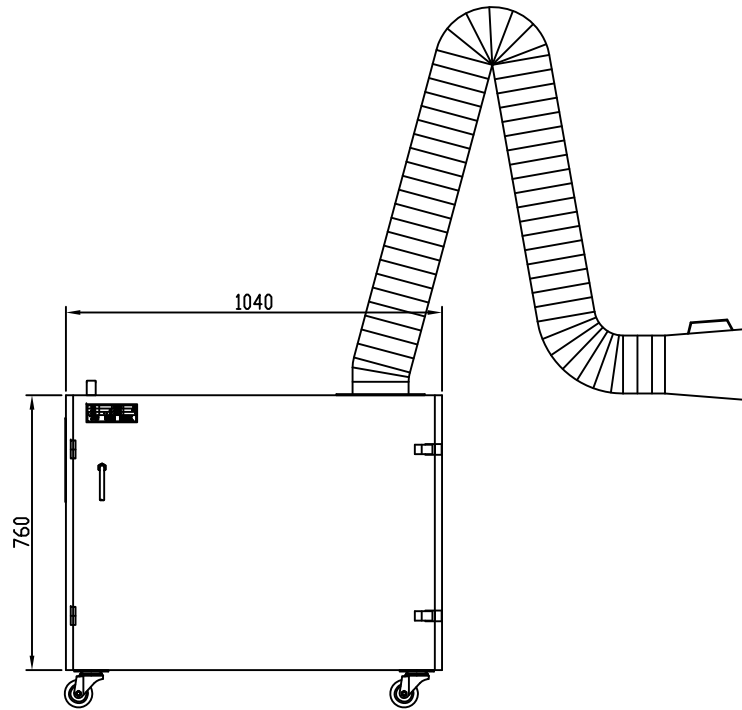
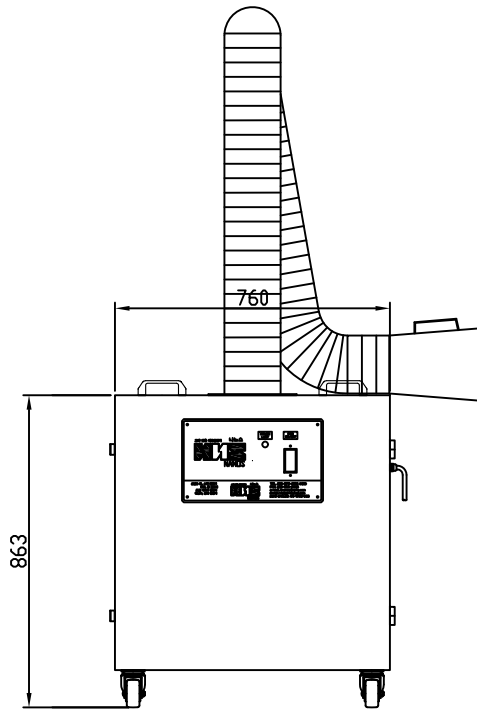

\*\*\* PAINT COLOR \*\*\*  
 BODY : EX8816(S) 5Y 7/1  
 DOOR : EX8816-DIC546 1/2

|  |          |       |          |                    |
|--|----------|-------|----------|--------------------|
| <br>2004년 설립된 나노스<br>나노스<br>2004년 설립된 나노스<br>나노스 | SIZE     | A3    | CUSTOMER | -                  |
|  | SCALE    | 1 / 1 | TITLE    | HUM DUST COLLECTER |
| DRAWN  | APPROVED | -     | NANOS    | DWG. NO.           |
| -  | -        | -     | NHM-30   |                    |